

# Application Note



Akademie věd České republiky  
Ústav teorie informace a automatizace AV ČR, v.v.i.

## Full HD Toshiba Video Sensor Platform with Automotive Grade Arm Zynq on TE0720-03-1QF SoM on TE0701-05 Carrier

Jiří Kadlec, Zdeněk Pohl, Lukáš Kohout  
[kadlec@utia.cas.cz](mailto:kadlec@utia.cas.cz) , [xpohl@utia.cas.cz](mailto:xpohl@utia.cas.cz) , [kohoutl@utia.cas.cz](mailto:kohoutl@utia.cas.cz)  
phone: +420 2 6605 22 16  
UTIA AV ČR, v.v.i.

### Revision history:

Rev.	Date	Author	Description
1	06.07.2016	Jiří Kadlec	Evaluation package for Xilinx SDK 2015.4

### Acknowledgements:

This work has been partially supported by:  
ENIAC JU project PANACHE No. 621217 and by related MEYS (CZ NFA) project 7H14006;

# Table of contents

## Full HD Toshiba Video Sensor Platform with Automotive Grade Arm Zynq on TE0720-03-1QF SoM on TE0701-05 Carrier 1

<b>1. Summary</b> .....	<b>3</b>
1.1 Key features .....	3
1.2 Project sh01: Edge detection with single HW accelerator .....	4
1.3 Project sh02: Edge detection with two HW accelerators .....	5
1.4 Project sh03: Edge detection with three HW accelerators.....	6
1.5 Project md01: Motion detection with single chain of HW accelerators.....	7
1.6 Project md02: Motion detection with two chains of HW accelerators .....	8
<b>2. Installation of evaluation package</b> .....	<b>9</b>
2.1 Import of SW projects in Xilinx SDK 2015.4.....	9
2.2 HW setup.....	12
2.3 Test demos .....	13
<b>3. References</b> .....	<b>17</b>
<b>4. Evaluation license</b> .....	<b>18</b>
<b>Disclaimer</b> .....	<b>19</b>

## Table of figures

Figure 1: Full HD Toshiba video sensor evaluation platform with Automotive Zynq SoM .....	3
Figure 2: Project sh01 - Edge detection with single HW accelerator .....	4
Figure 3: Project sh01 - Energy per frame reduction and used HW resources. ....	4
Figure 4: Project sh02 - Edge detection with two HW accelerators .....	5
Figure 5: Project sh02 - Energy per frame reduction and used HW resources. ....	5
Figure 6: Project sh03 - Edge detection with three HW accelerators.....	6
Figure 7: Project sh03 - Energy per frame reduction and used HW resources. ....	6
Figure 8: Project md01 - Motion detection with single HW accelerator data path .....	7
Figure 9: Project so01 - Energy per frame reduction and used HW resources. ....	7
Figure 10: Project md02 - Motion detection with two HW accelerator data paths .....	8
Figure 11: Project so02 - Energy per frame reduction and used HW resources. ....	8
Figure 12: Select the SDK Workspace.....	9
Figure 13: Import Existing Projects into Workspace .....	10
Figure 14: Select “Copy projects into workspace” and finish the import of all projects.....	11
Figure 15: All projects are compiled in debug mode.....	12
Figure 16: Serial console. Reset board and stop autoboot.....	13
Figure 17: Download bitstream to the PL part of Zynq. ....	14
Figure 18: Select demo application for debug.....	15
Figure 19: Debug stops at first executable line of Arm Cortex A9 code.....	15

# 1. Summary

## 1.1 Key features

Video processing in automotive applications require processors capable to operate in extended temperature range. This application note describes HW platform performing edge detection and motion detection video processing for Toshiba colour video sensor with fixed Full HD resolution (1920x1080p60) with processing performed by Xilinx Zynq automotive xa7z020-1Q located on the TE0720-02-1QF SoM from Trenz [1].

Arm Cortex A9 processor of Xilinx Zynq part xa7z020-1Q is performing initialisation and synchronisation of the video processing chain. Program and the FPGA image is downloaded to the board from the Xilinx SDK 2015.4 via USB JTAG to the 1GB DDR3 located on the Zynq system on module. System can be also started directly from the SD card. Arm processor initiates the IP cores in the programmable logic (PL) part of the Zynq part xa7z020-1Q. It also initiates the Toshiba video sensor and the HDMI video output to monitor with fixed Full HD resolution (1920x1080p60).

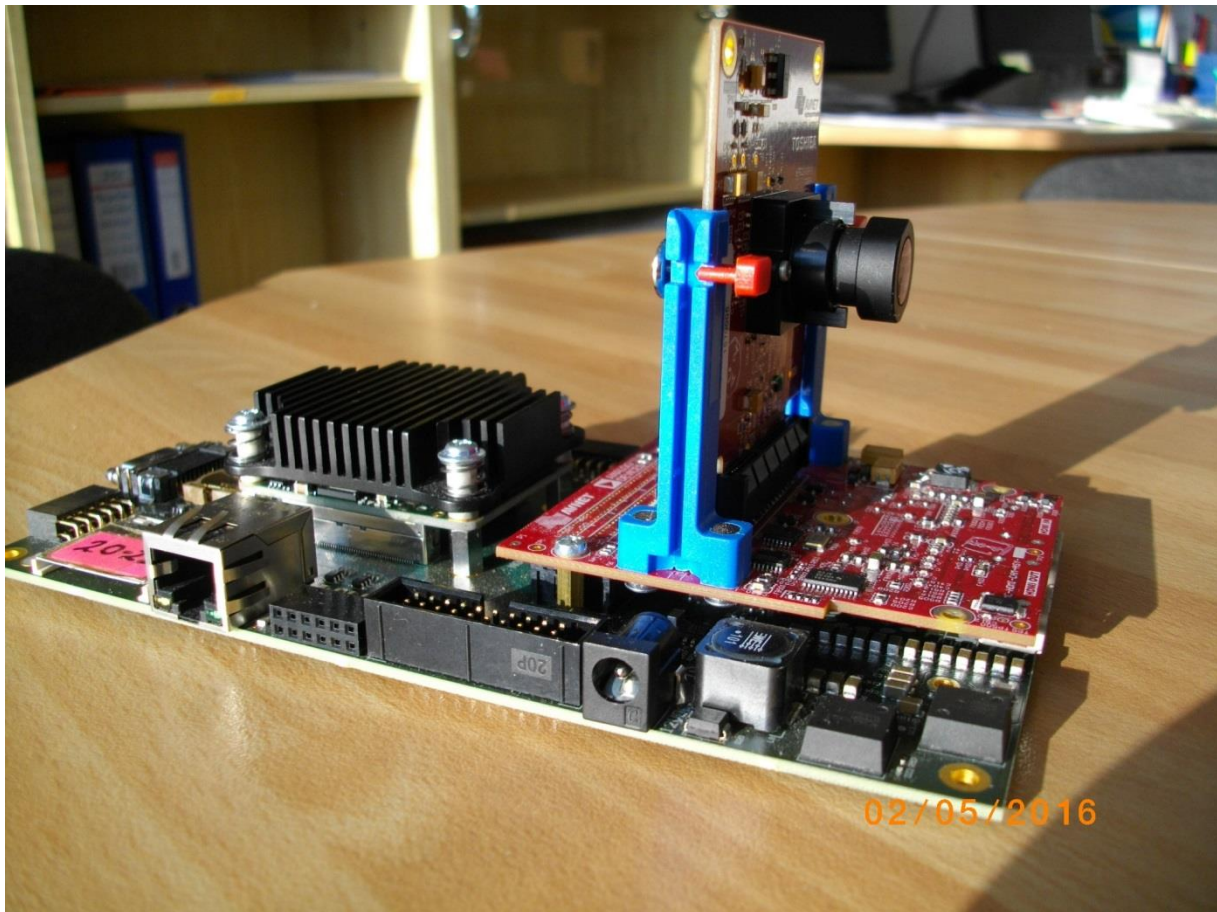

Figure 1: Full HD Toshiba video sensor evaluation platform with Automotive Zynq SoM

- Raw video data are provided by the Toshiba video sensor.
- Data are processed into the YCrCb 16 bit per pixel format and stored by Video DMA (VDMA) to input video frame buffers (VFBs) defined in the DDR3.
- HW DMA controller(s) send data from the input VFBs to the processing accelerators in PL.
- Another DMA controller(s) send processed data from HW to the output VFBs in DDR3.
- Second part of the VDMA is sending data to the HDMI display with resolution 1280x1024p60.

## 1.2 Project sh01: Edge detection with single HW accelerator

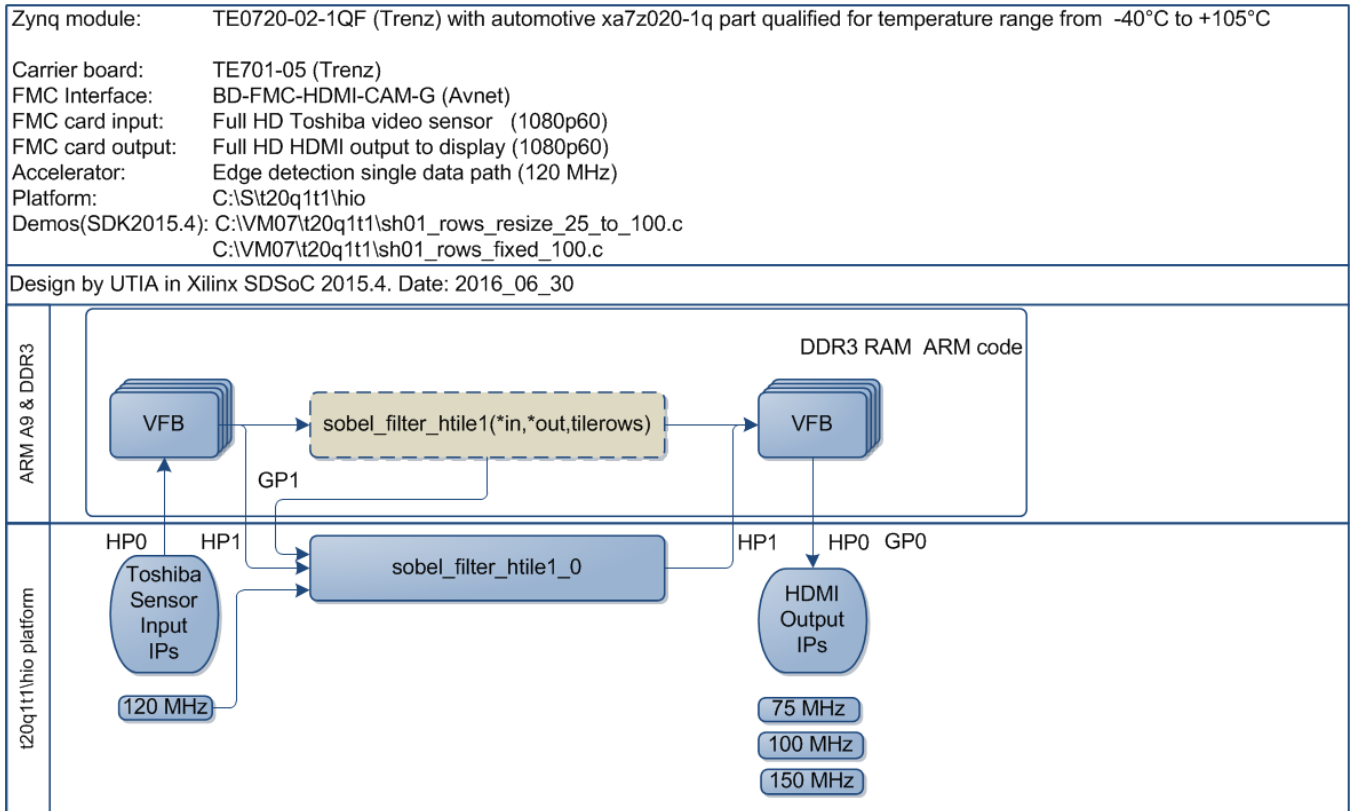

Figure 2: Project sh01 - Edge detection with single HW accelerator

### TE0720-02-1QF Sobel 1x

Energy per one frame (SW): 966.05 mJ

Energy per one frame (HW): 204.03 mJ

Energy per frame reduction: **4.73 x**

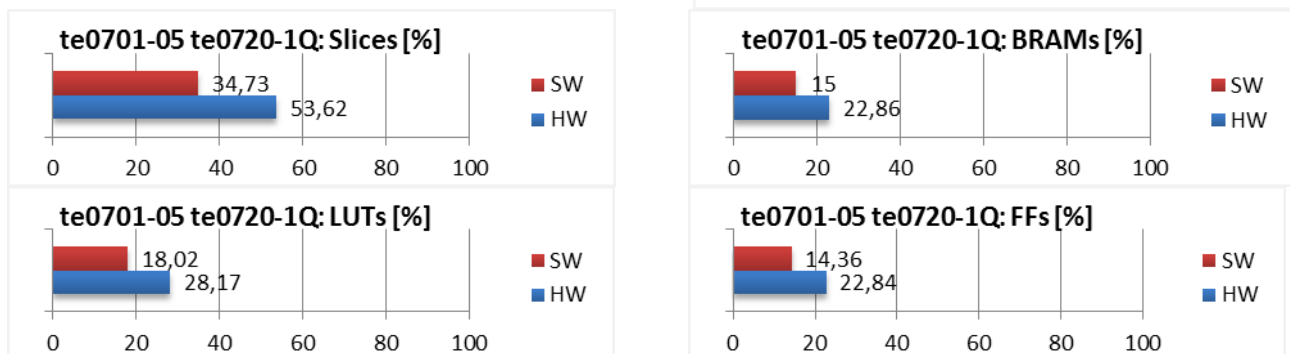

Figure 3: Project sh01 - Energy per frame reduction and used HW resources.

### 1.3 Project sh02: Edge detection with two HW accelerators

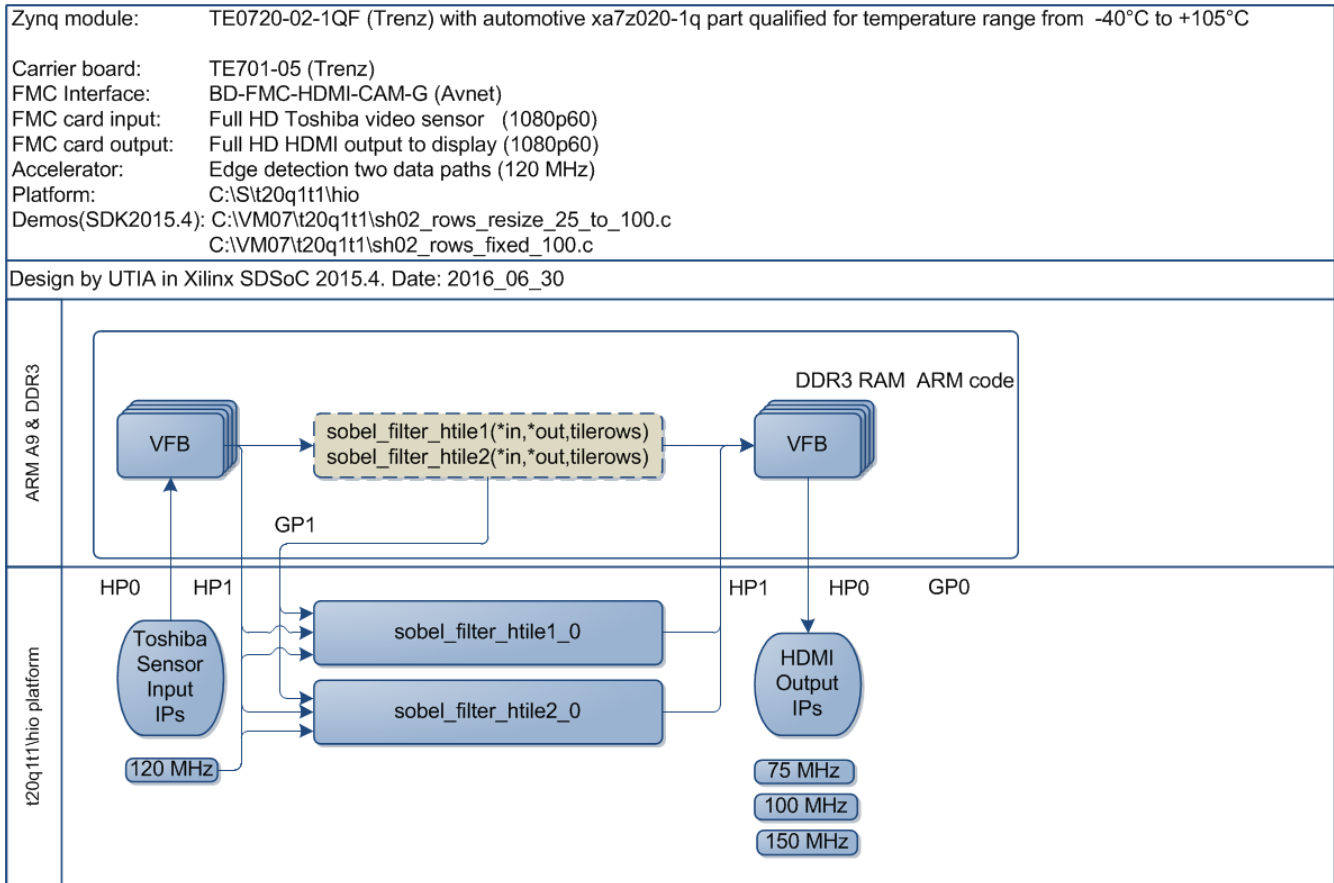

Figure 4: Project sh02 - Edge detection with two HW accelerators

#### TE0720-02-1QF Sobel 2x

Energy per one frame (SW): 966.05 mJ

Energy per one frame (HW): 124.60 mJ

Energy per frame reduction: **7.75 x**

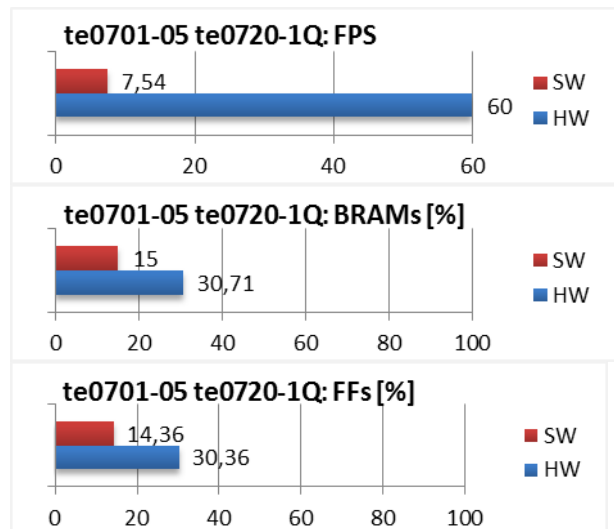
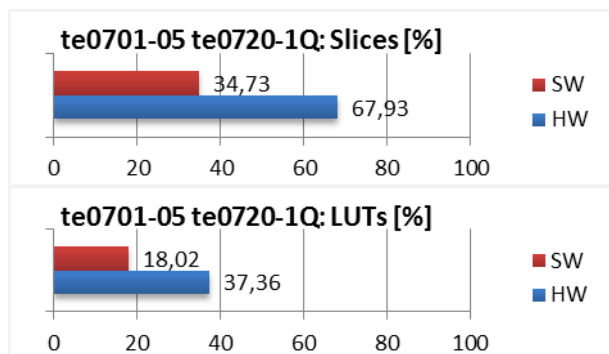

Figure 5: Project sh02 - Energy per frame reduction and used HW resources.



## 1.4 Project sh03: Edge detection with three HW accelerators

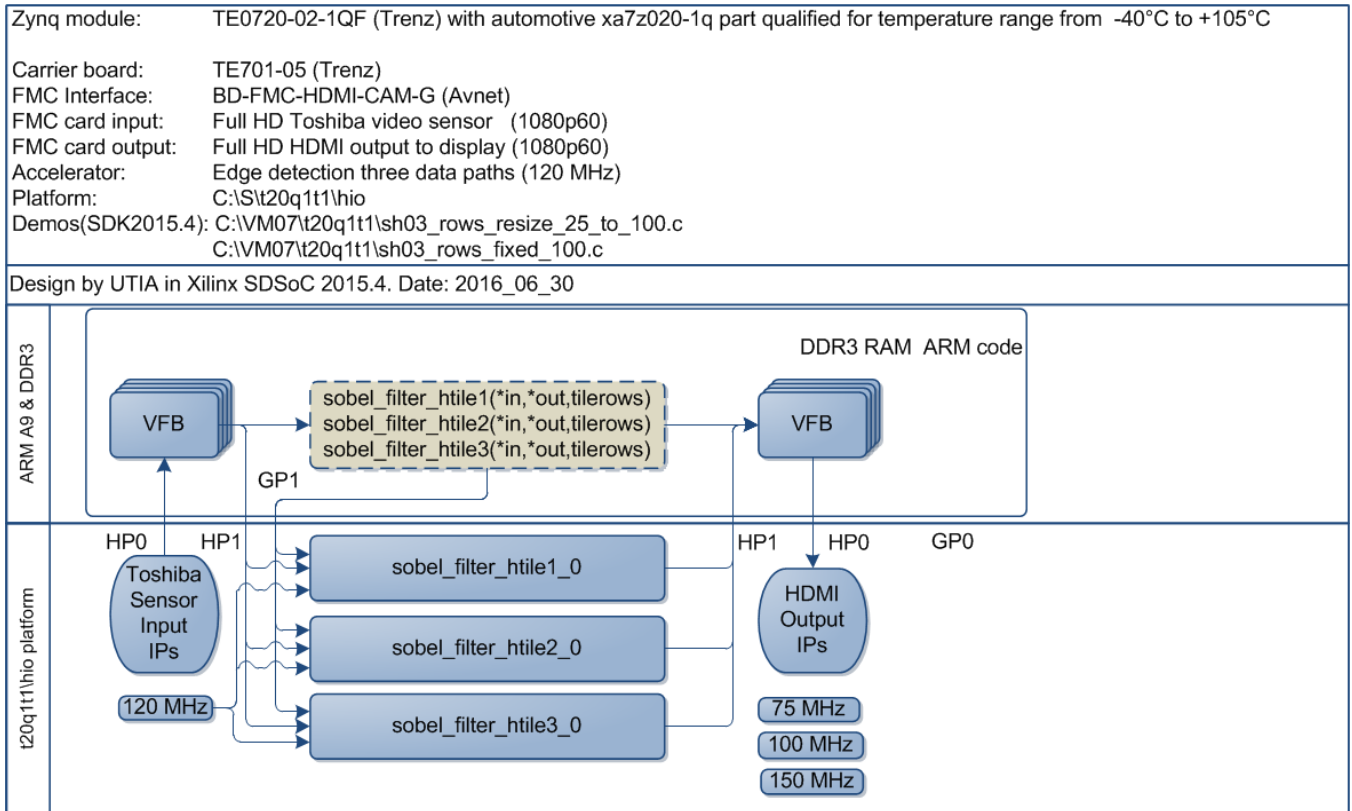

Figure 6: Project sh03 - Edge detection with three HW accelerators

### TE0720-02-1QF Sobel 3x

Energy per one frame (SW): 966.05 mJ

Energy per one frame (HW): 125.6 mJ

Energy per frame reduction: **7.69 x**

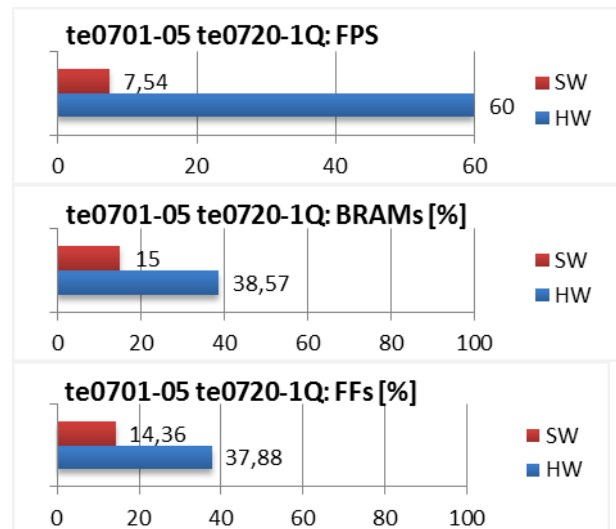
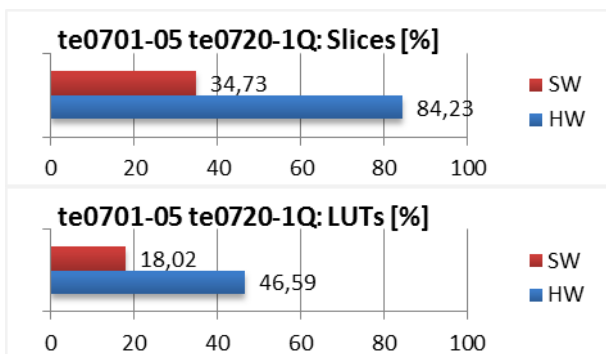

Figure 7: Project sh03 - Energy per frame reduction and used HW resources.

## 1.5 Project md01: Motion detection with single chain of HW accelerators

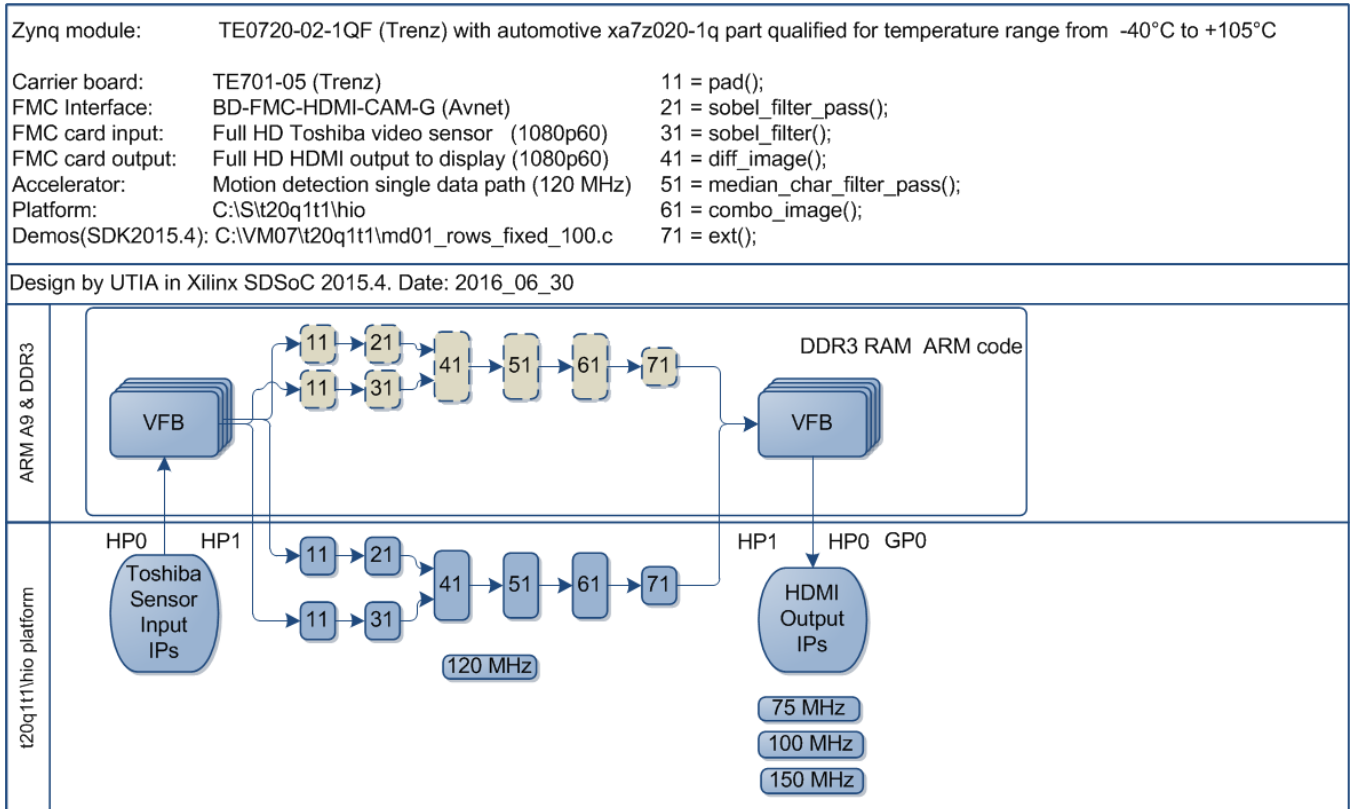

Figure 8: Project md01 - Motion detection with single HW accelerator data path

### TE0720-02-1QF Motion Detection 1x

Energy per one frame (SW): 6252.1 mJ

Energy per one frame (HW): 214.34 mJ

Energy per frame reduction: **29.16 x**

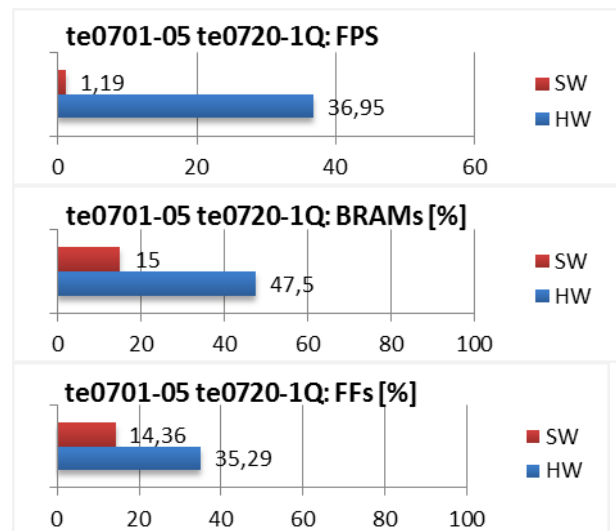
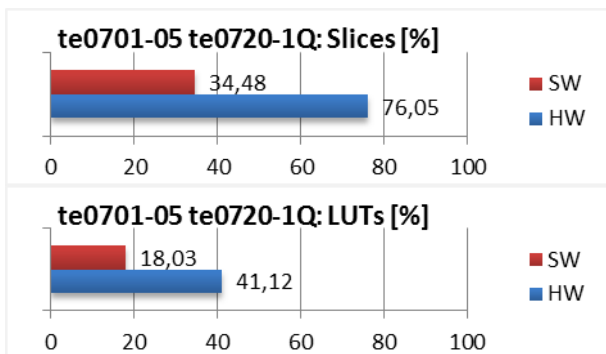

Figure 9: Project so01 - Energy per frame reduction and used HW resources.





## 2. Installation of evaluation package

### 2.1 Import of SW projects in Xilinx SDK 2015.4

Unzip the evaluation package to directory of your choice.  
The directory **C:\VM\_07** will be used in this application note.  
**C:\VM\_07\t20q1t1\_V54\_IMPORT**

Create empty directory for Xilinx SDK workspace.  
**C:\VM\_07\t20q1t1**

Start Xilinx SDK 2015.4 and select the directory for the SDK 2015.4 workspace. See Figure 12.  
Select **C:\VM\_07\t20q1t1**

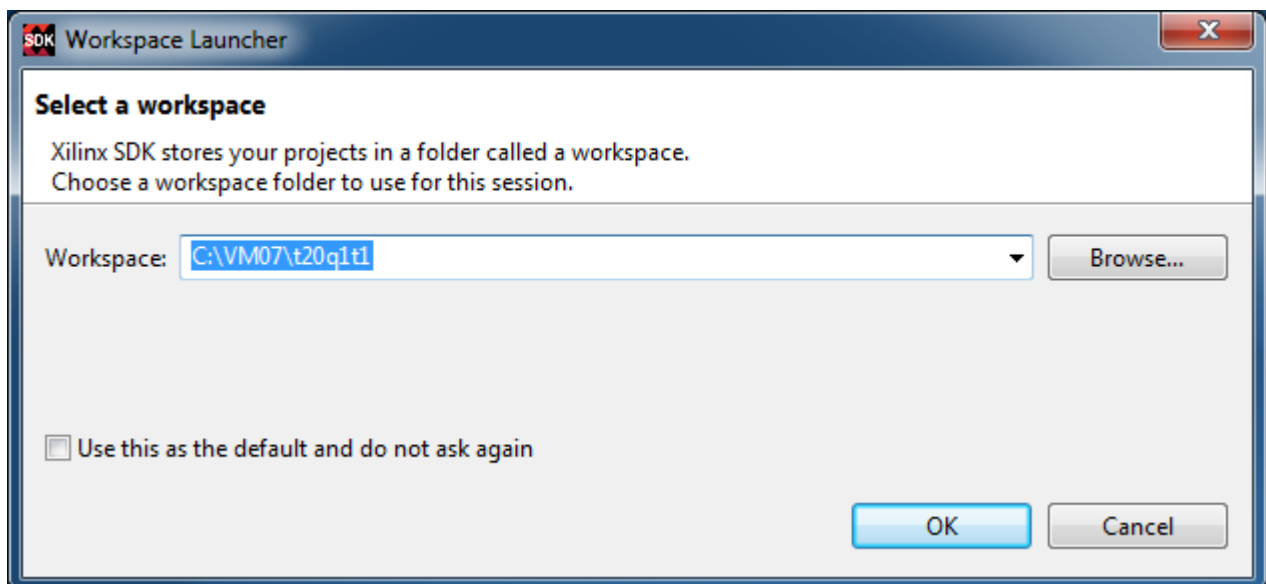

Figure 12: Select the SDK Workspace

HW and SW projects can be imported into SDK now. Select:

**File -> Import -> General -> Existing Projects into Workspace**  
Click on Next button. See Figure 13.

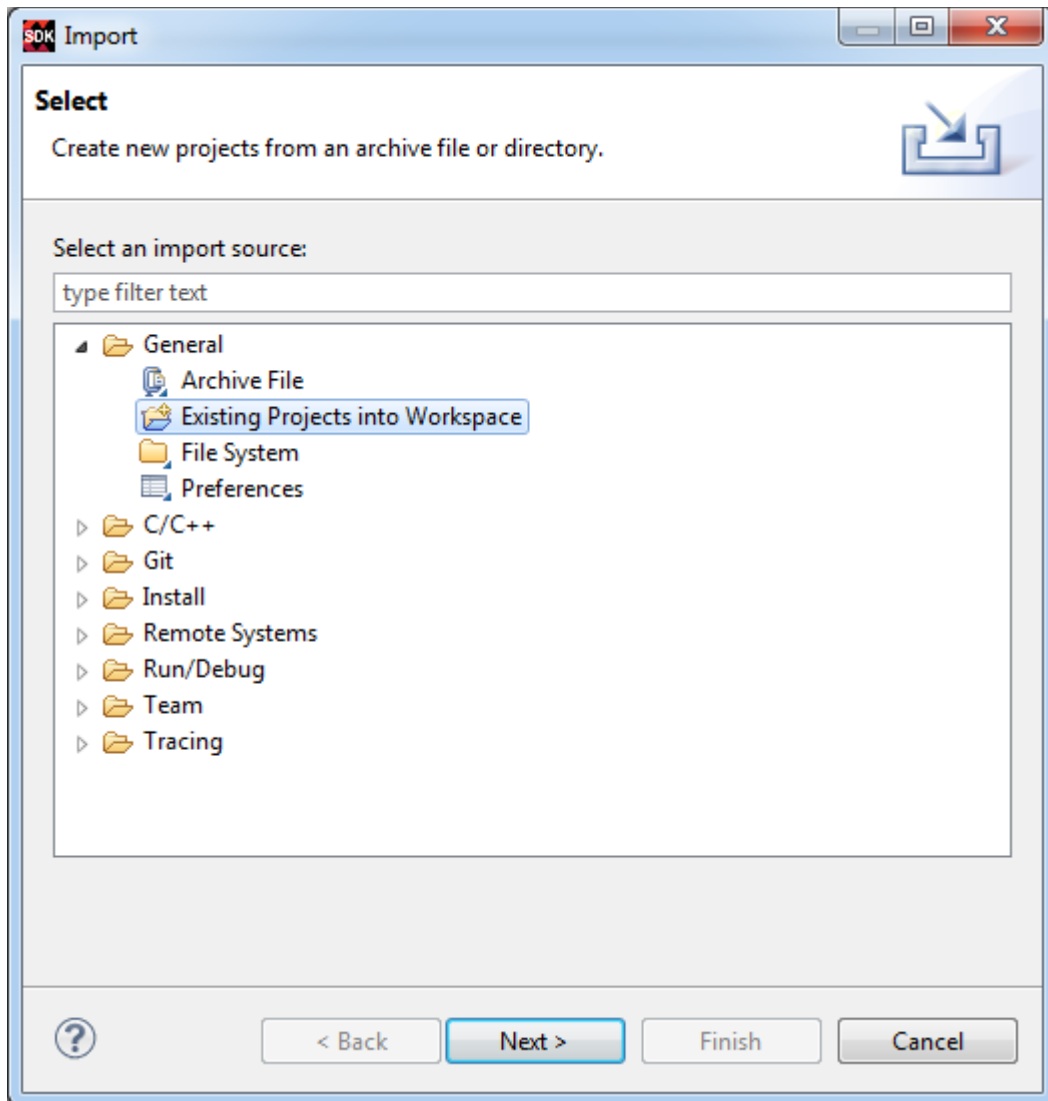

Figure 13: Import Existing Projects into Workspace

Type directory with projects to be imported. See Figure 14.

**C:\VM\_07\t20q1t1\_V54\_IMPORT**

Set the “**Copy projects into workspace**” check box.

Click on Finish button. See Figure 14.

Process of compilation will start automatically. This first compilation of all SDK SW projects can take several minutes to finish. It should finish without errors.

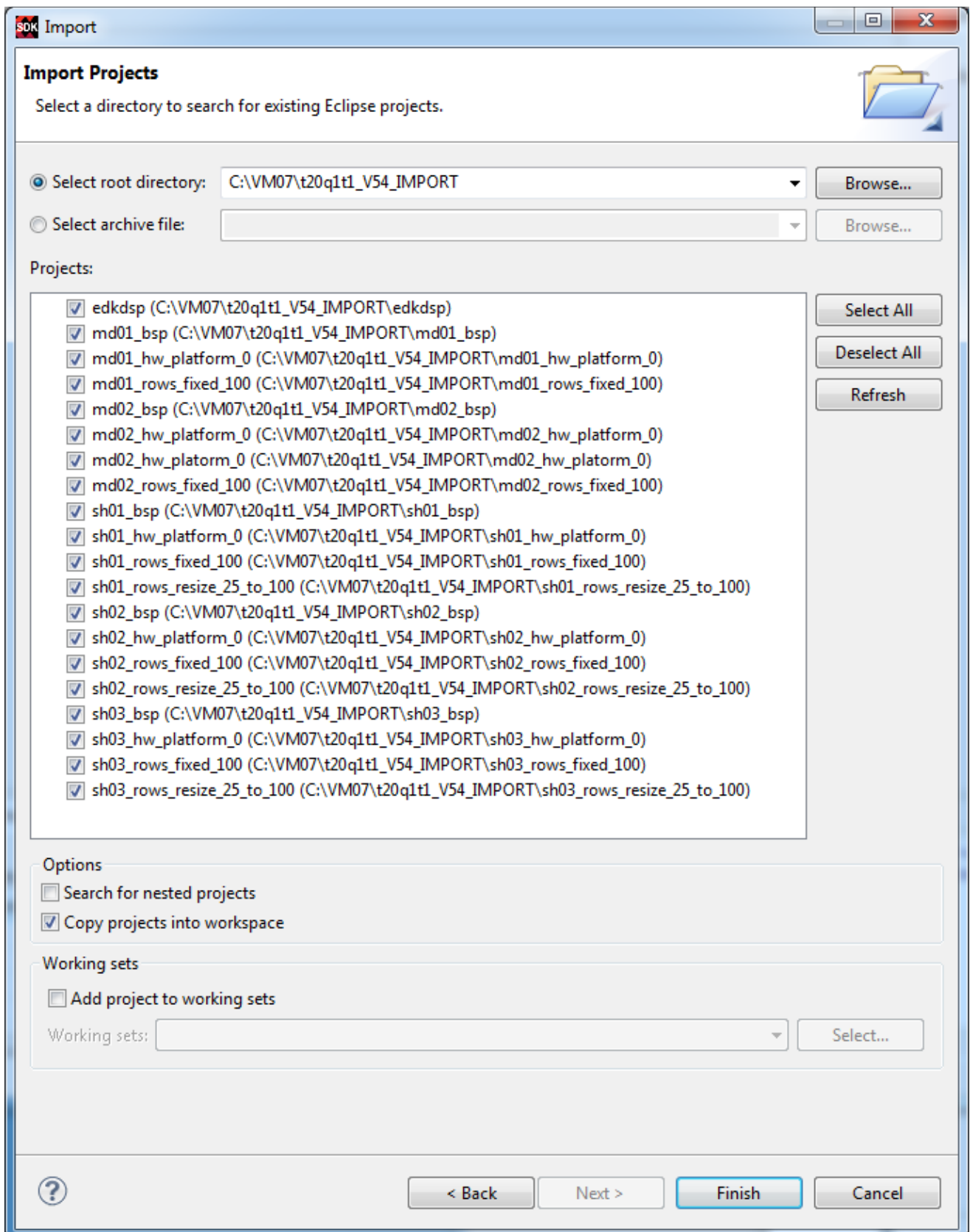

Figure 14: Select “Copy projects into workspace” and finish the import of all projects.

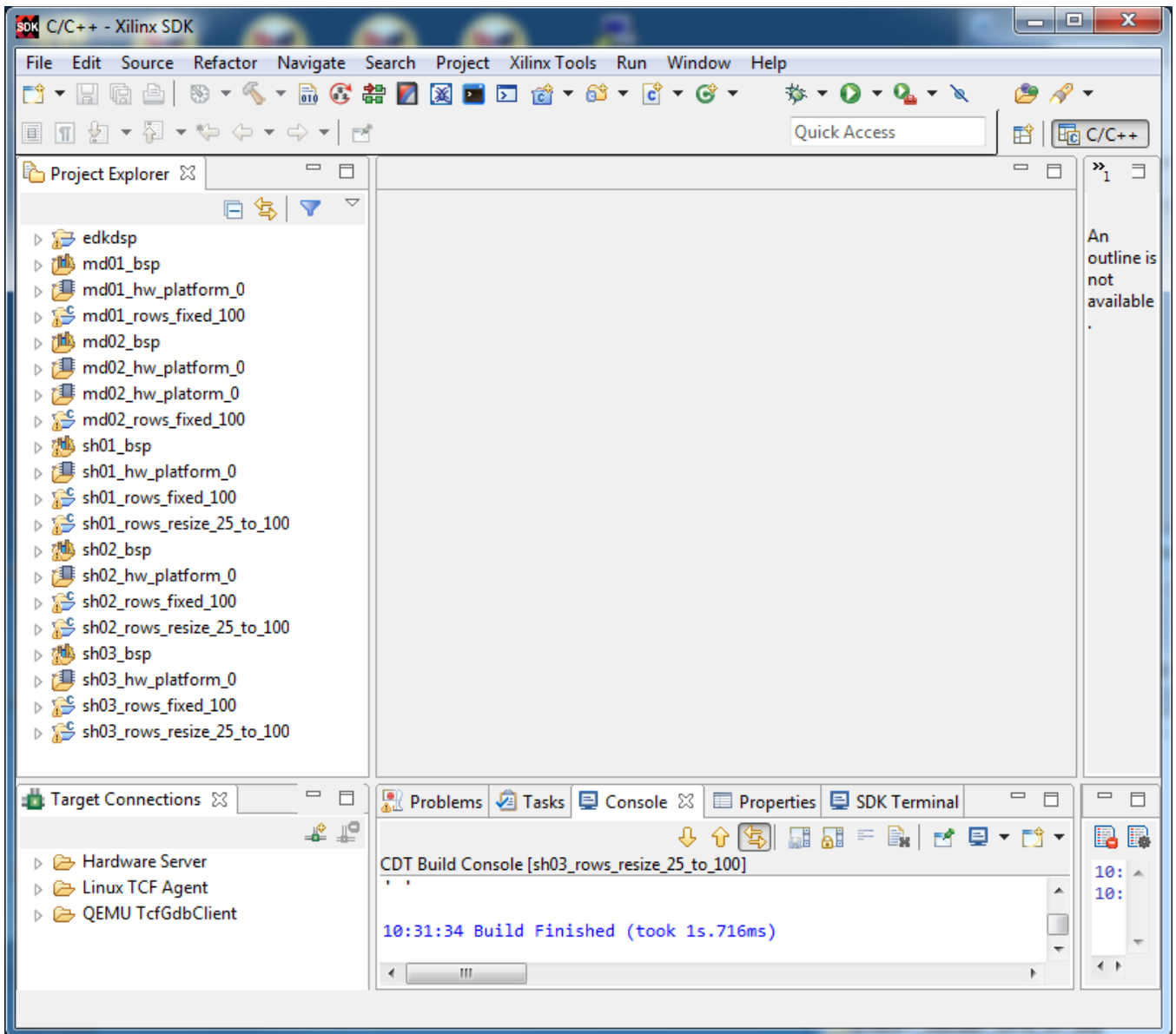

Figure 15: All projects are compiled in debug mode.

SDK 2015.4 compiles SW of all imported demos in debug mode.

## 2.2 HW setup

HW setup is using commercially accessible components [1], [2], [3], [4], [5]:

<b>TE0720-03-1QF</b> ; Part: XA7Z020-1CLG484Q; 1 GByte DDR; Automotive;	Price: €299,00 [1]
<b>Heatsink for TE0720</b> , spring-loaded embedded;	Price: €19.00 [2]
<b>TE0701-05 Carrier Board</b> for Trenz Electronic 7 Series;	Price: €249.00 [3]
<b>AES-FMC-HDMI-CAM-G</b> FMC card with HDMI I/O and CAM interface	Price: \$250.00 [4]
Toshiba Industrial 1080P60 Camera Module;	Price \$229.00 [5]

HW Options:

**TE0701-05** can be replaced by **TE0701-04** (Same Price, both boards from Trenz) [3].

Trenz TE0701-04 or TE0701-05 carriers require modifications to run the FMC Imageon carrier AES-FMC-HDMI-CAM-G with Zynq TE0720-03-1QF system on module. The modification is related to the swapped polarity of the differential clock signal for the FMC board. Evaluation HW systems with carriers TE0701-04 or TE0701-05 provided by UTIA have these modifications already done.

UTIA can implement these HW modifications for the original Trenc TE0701-04 and TE0701-05 carriers. This requires written e-mail request to [kadlec@utia.cas.cz](mailto:kadlec@utia.cas.cz). Request will be first confirmed by UTIA. The interested party has to cover the cost of shipment of the carrier board to/from UTIA. Modification can be done in 5 working days and it is offered free of charge.

## 2.3 Test demos

To test demos follow these steps:

- Insert the Toshiba color image sensor to the connector on the Imageon board.
- Connect Full HD monitor (supporting 1080p60) resolution by HDMI cable to the HDMI OUT on the Imageon FMC card.
- Switch the monitor ON.
- Connect the carrier board by USB-to-microUSB cable to PC to support JTAG serial link and the standard serial terminal.
- Connect power supply (DC 12V).
- Open and configure the standard serial terminal client (PuTTY or similar) on PC. (Speed: 115200 baud; Data bits: 8; Stop bits: 1; Parity: None; Flow control: None.)
- Reset the board. Board will start first stage boot loader from internal flash as set up by Trenc. It is writing messages to the serial terminal. On request, "Hit any key to stop autoboot" type any key to stop the auto-boot of linux.
- If you need to switch-off the power, close first the serial terminal on the PC. This will help to avoid problems

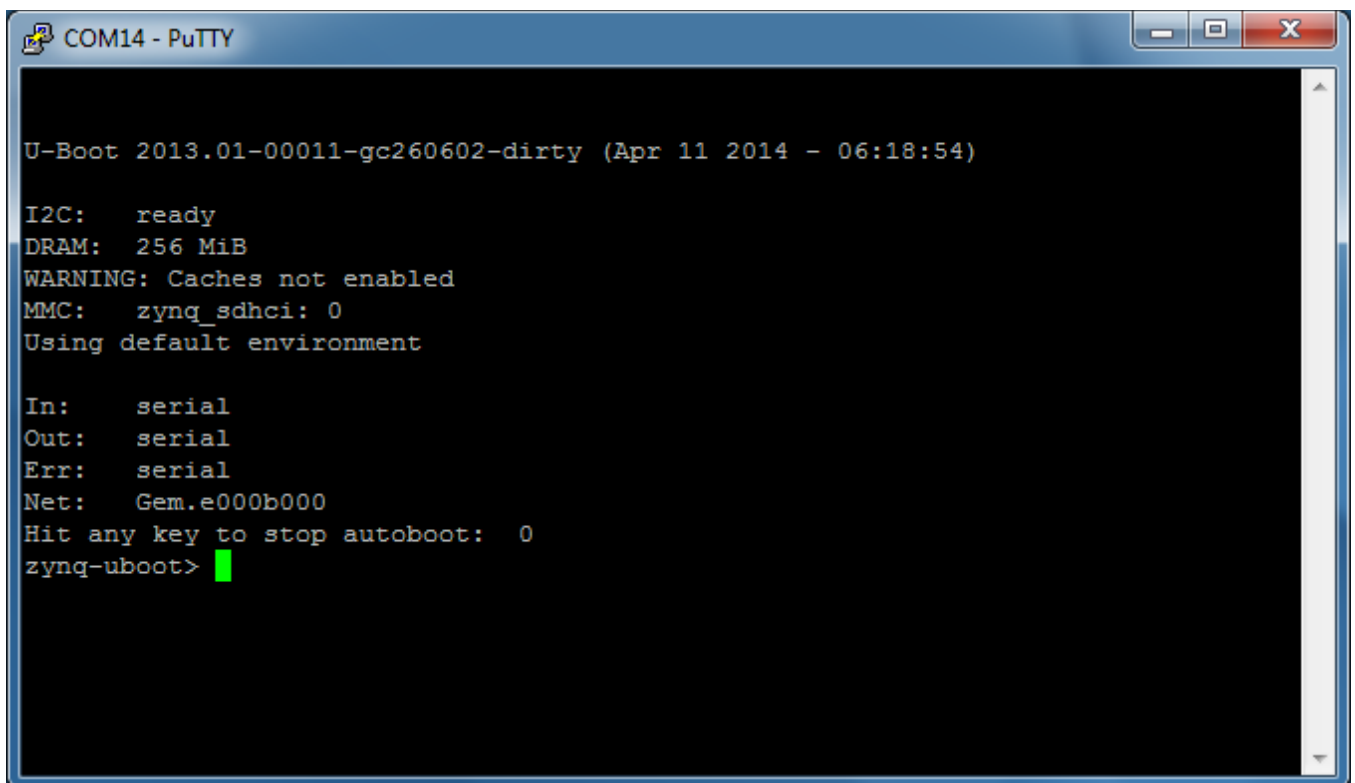

```
COM14 - PuTTY
U-Boot 2013.01-00011-gc260602-dirty (Apr 11 2014 - 06:18:54)

I2C:   ready
DRAM:  256 MiB
WARNING: Caches not enabled
MMC:   zynq_sdhci: 0
Using default environment

In:    serial
Out:   serial
Err:   serial
Net:   Gem.e000b000
Hit any key to stop autoboot:  0
zynq-uboot>
```

Figure 16: Serial console. Reset board and stop autoboot.

Download bitstream to the board. Demo **sh01\_rows\_fixed\_100** will be used as an example. The **bitstream.bit** for demo **sh01** is located in the directory: **C:\VM\_07\t20i2p1\sh01\_hw\_platform\_0**

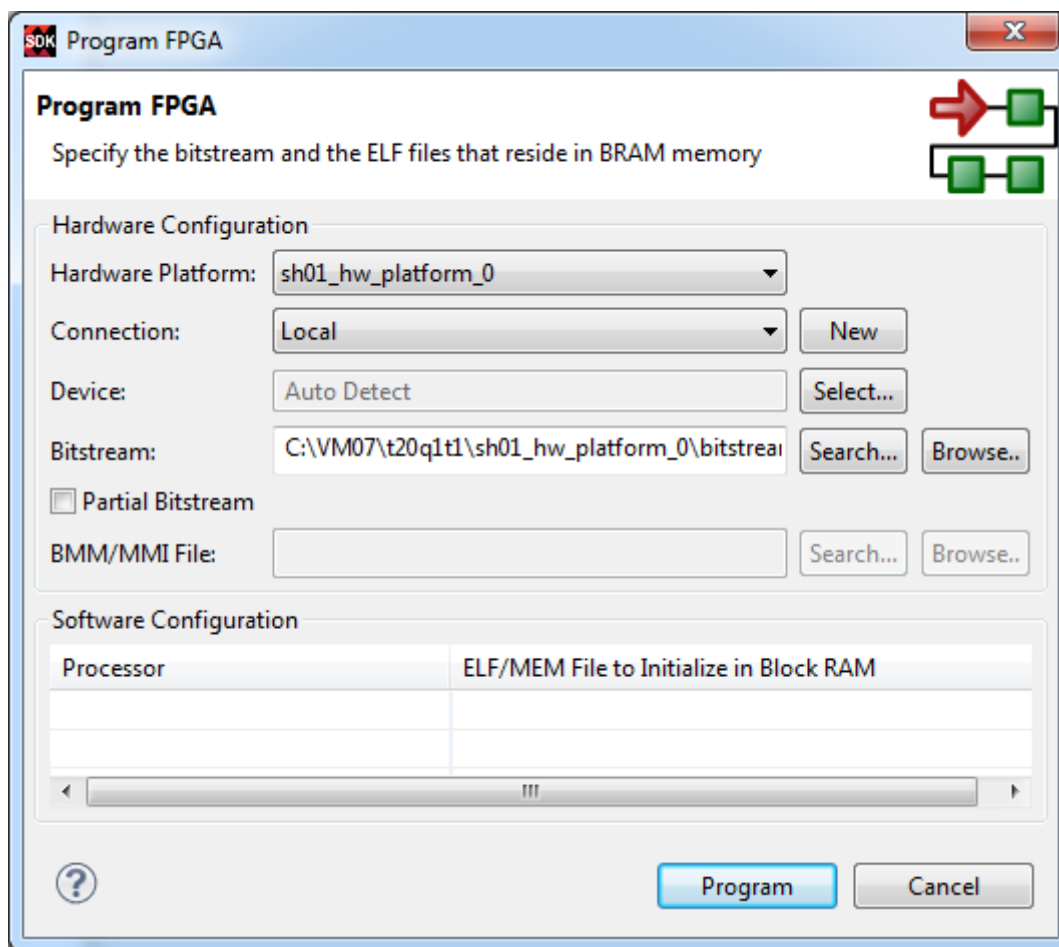

Figure 17: Download bitstream to the PL part of Zynq.

Select Program to download the bitstream to the PL part of Zynq via the USB cable in JTAG mode.



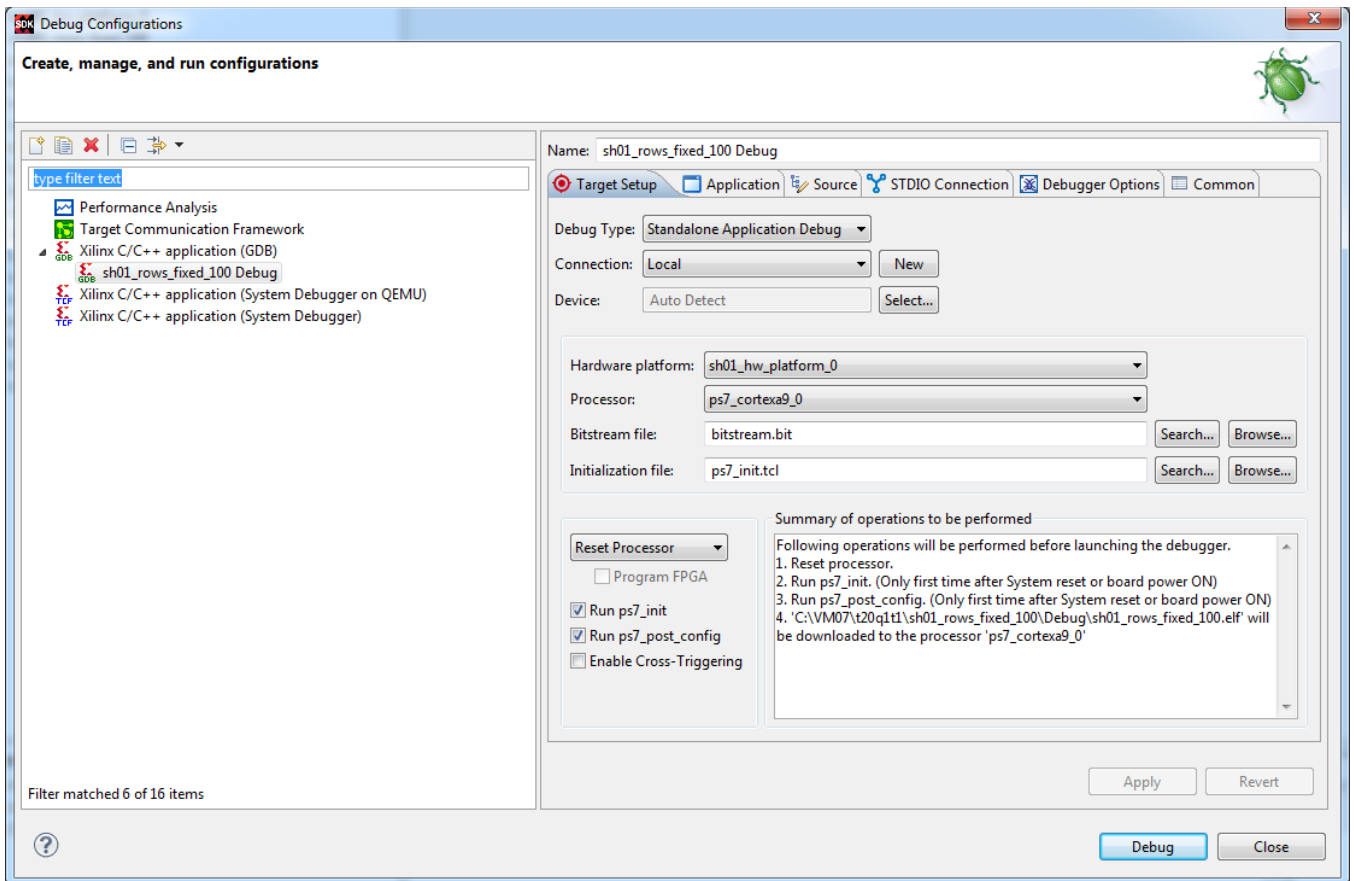

Figure 18: Select demo application for debug.

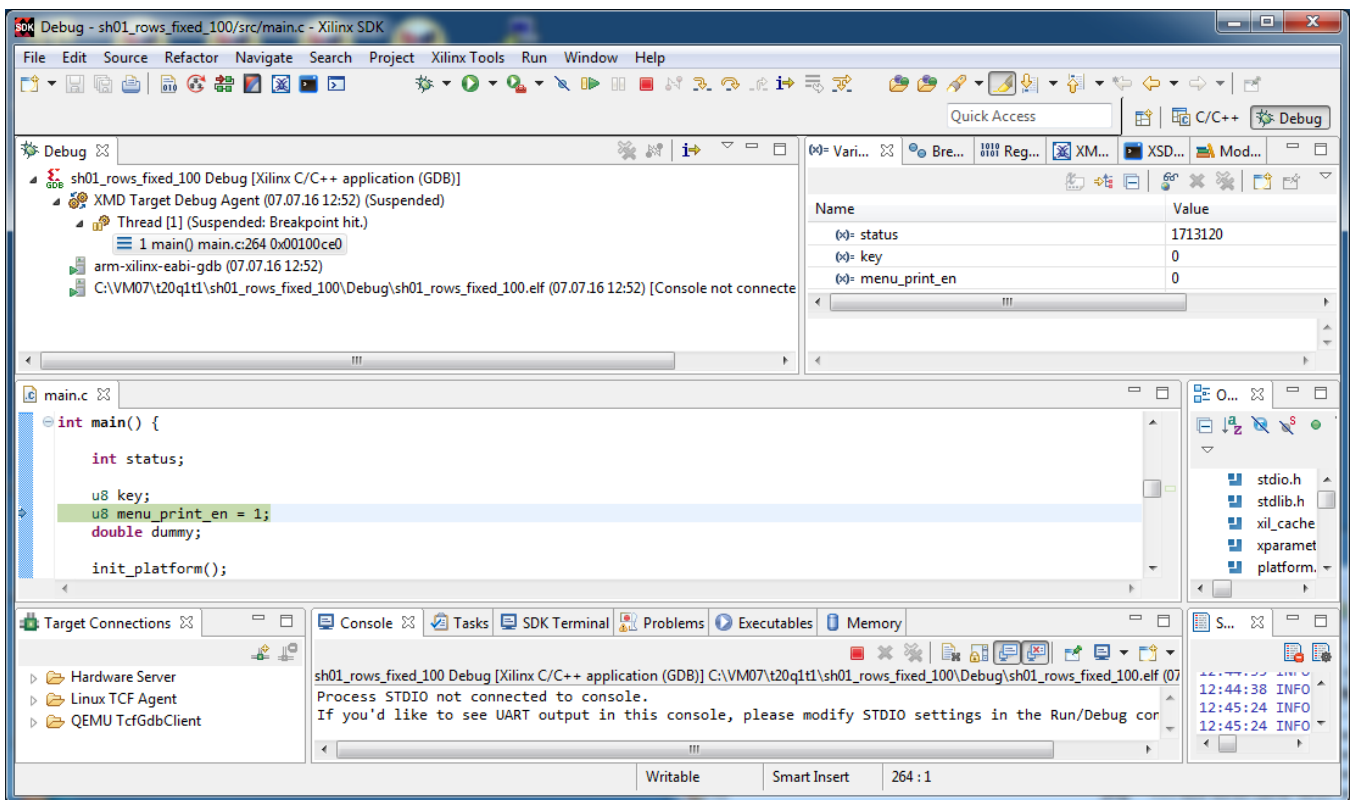

Figure 19: Debug stops at first executable line of Arm Cortex A9 code.

- All evaluation demos can be also compiled into Release versions with optimisation set to -O2 or -O3.
- All evaluation demos can boot directly from SD card. FSBL projects can use the standard project template as provided by the SDK 2015.4
- Demo **sh01\_rows\_fixed\_100** works on complete frame with single HW accelerator data path
- Demo **sh01\_rows\_resize\_25\_to\_100** works with identical HW. But SW scales dynamically the number of lines to be processed. This is scaling from  $\frac{1}{4}$  of frame to the complete frame. Part of the frame which is not processed is automatically propagating the input video signal via the cyclic structure of 8 video frame buffers. The HW data movers are instructed about the number of lines to be processed. SW is writing this information to an AXI-lite configuration register of the data mover IP core.
- Demos **sh02\_rows\_fixed\_100** and **sh02\_rows\_resize\_25\_to\_100** work with 2 data paths.
- Demos **sh03\_rows\_fixed\_100** and **sh03\_rows\_resize\_25\_to\_100** work with 3 data paths.
- Demos **md01\_rows\_fixed\_100** and **md02\_rows\_fixed\_100** work with one and two HW video processing chains. These HW chains have only fixed set of processed lines (1x 100% and 2x 50% of the frame).

### 3. References

---

- [1] TE0720-03-1QF; Part: XA7Z020-1CLG484Q; 1 GByte DDR; Automotive; Price: €299,00.  
<https://shop.trenz-electronic.de/en/TE0720-03-1QF-Xilinx-Zynq-module-ind.-temp.-range-with-Automotive-XA7Z020-1CLG484Q>
- [2] Heatsink for TE0720, spring-loaded embedded; Price: €19.00.  
<https://shop.trenz-electronic.de/en/26922-Heatsink-for-TE0720-spring-loaded-embedded?c=38>
- [3] TE0701-05 Carrier Board for Trenz Electronic 7 Series; Price: €249.00.  
<https://shop.trenz-electronic.de/en/TE0701-05-Carrier-Board-for-Trenz-Electronic-7-Series>
- [4] AES-FMC-HDMI-CAM-G Price: \$250.00.  
<http://products.avnet.com/shop/en/ema/3074457345623664802>
- [5] Toshiba Industrial 1080P60 Camera Module; Price \$229.00.  
[http://zedboard.org/sites/default/files/product\\_briefs/PB-AES-CAM-TOSH-1080P-G-v5-web.pdf](http://zedboard.org/sites/default/files/product_briefs/PB-AES-CAM-TOSH-1080P-G-v5-web.pdf)

## 4. Evaluation license

---

The **evaluation version of the package** can be downloaded from UTIA www pages free of charge for evaluation of HW accelerated edge detection and motion detection algorithms for the Full HD video sensor on TE0720-03-1QF module [1] located on TE0701-05 carrier [3].

The evaluation package includes SDK 2015.4 SW projects with C source code for Arm Cortex A9 processor (32bit) in standalone mode.

The evaluation package includes these static libraries for Arm Cortex A9 processor (32bit) for standalone mode:

<b>libfmc_imageon.a</b>	SDK 2015.4 UTIA static library with interface functions for video IP cores
<b>libsh01.a</b>	SDSoC 2015.4 static library for HW accelerator in project sh01
<b>libsh02.a</b>	SDSoC 2015.4 static library for HW accelerator in project sh02
<b>libsh03.a</b>	SDSoC 2015.4 static library for HW accelerator in project sh03
<b>libmd01.a</b>	SDSoC 2015.4 static library for HW accelerator in project md01
<b>libmd02.a</b>	SDSoC 2015.4 static library for HW accelerator in project md02

These libraries have no time restriction.

Source code of these libraries is not provided in this evaluation package.

## Disclaimer

---

This disclaimer is not a license and does not grant any rights to the materials distributed herewith. Except as otherwise provided in a valid license issued to you by UTIA AV CR v.v.i., and to the maximum extent permitted by applicable law:

(1) THIS APPLICATION NOTE AND RELATED MATERIALS LISTED IN THIS PACKAGE CONTENT ARE MADE AVAILABLE "AS IS" AND WITH ALL FAULTS, AND UTIA AV CR V.V.I. HEREBY DISCLAIMS ALL WARRANTIES AND CONDITIONS, EXPRESS, IMPLIED, OR STATUTORY, INCLUDING BUT NOT LIMITED TO WARRANTIES OF MERCHANTABILITY, NON-INFRINGEMENT, OR FITNESS FOR ANY PARTICULAR PURPOSE; and

(2) UTIA AV CR v.v.i. shall not be liable (whether in contract or tort, including negligence, or under any other theory of liability) for any loss or damage of any kind or nature related to, arising under or in connection with these materials, including for any direct, or any indirect, special, incidental, or consequential loss or damage (including loss of data, profits, goodwill, or any type of loss or damage suffered as a result of any action brought by a third party) even if such damage or loss was reasonably foreseeable or UTIA AV CR v.v.i. had been advised of the possibility of the same.

### Critical Applications:

UTIA AV CR v.v.i. products are not designed or intended to be fail-safe, or for use in any application requiring fail-safe performance, such as life-support or safety devices or systems, Class III medical devices, nuclear facilities, applications related to the deployment of airbags, or any other applications that could lead to death, personal injury, or severe property or environmental damage (individually and collectively, "Critical Applications"). Customer assumes the sole risk and liability of any use of UTIA AV CR v.v.i. products in Critical Applications, subject only to applicable laws and regulations governing limitations on product liability.